

Flow of a fluid of grade two between two eccentric rotating spheres

By A. Abu-El-Hassan, M. Abdel Wahab, M. Y. El-Bakry,
Physics Department, Faculty of Science, Benha University and
M. Zidan, Physics Department, Faculty of Science, Cairo University

1. Introduction

The application of solutions and melts of macromolecular materials in almost all branches of industries requires a very careful investigation of the mechanical properties of these materials.

Within the frame of non-linear theories of constitutive equation, whether macroscopic or microscopic, these properties are designated by a set of parameters known as material constants. The retarded motion approximation for the theory of simple fluids produces, as second approximation, the fluid of grade two. These fluids are characterized by three parameters; namely the coefficient of viscosity, μ , and the two elastic constants α_1 and α_2 which are related to the two normal stress differences ($S_{22} - S_{11}$), and ($S_{11} - S_{33}$). The determination of these material parameters is done using proper devices, known as rheometers.

In general, the rheometer is based on the solution of a specific boundary value problem which allows a number of experimental measurements sufficient to determine a specific set of material parameters.

One of the earlier trials to solve a specific boundary value problem adequate for the characterization of the material constants of a fluid of grade three was carried out by Giesekus [1]. He calculated the forces and the torques acting on a sphere which undergoes simultaneous rotational and transitional creeping motion in a fluid of grade three. The expected measurements were interrelated to the material constants, however, the practical realization of a corresponding device has never been carried out.

Another successful trial, which led to the construction of the eccentric cylinder rheometer [2, 3], was the solution of the boundary value problem of a fluid of grade two moving in the annular region between two eccentric cylinders. Besides simplicity of the construction, this rheometer allows reliable measurements for the elastic constant α_1 .

The present work deals with another boundary value problem which promises to create a successful rheometer. The steady state isochoric flow of a fluid of grade two moving in the annular region between two eccentric spheres is investigated and the velocity field is computed [4]. This set up provides good facilities for rheological measurements. In practical design, the inner sphere can be rotated while the torques and forces acting on the outer stationary sphere can be measured and used to determine the material constants. The spherical symmetry is very useful in avoiding the end effects, as present in the case of finite cylinders, which require complicated precautions.

A large number of theoretical and experimental works has been done on the viscous flow between two eccentric spheres. However, to the best of our knowledge, the motion of viscoelastic fluids is not considered [5]. Jeffery [6], Stimson and Jeffery [7] solved the stationary rotational viscous flow in the so called axisymmetrical case, where the rotation takes place about the common diameter of the two spheres. These authors employed the bispherical system of coordinates which appears to be the most appropriate one. Noteworthy, is that this system can be used in the case when the two spheres are external to each other, as well as the case when the sphere encloses the other. Majumdar [8] considered the non-axisymmetrical problem of separate spheres in an incompressible viscous fluid when one of the spheres rotates slowly about an axis perpendicular to their line of centers and the other sphere remains at rest. Due to the complications associated with the non-axisymmetry of the problem, the solution is obtained by applying special approximation methods. Munson [9] solved the axisymmetrical case for stationary slow viscous flow using spherical polar coordinates instead of the bispherical coordinates. The complications which arise due to the disappropriateness of the used system of coordinates to the boundary conditions required a series of computational approximations. Menguturk and Munson [10] constructed a device in order to realize experimentally the results obtained in the previous paper. They compared the theoretical values of the torques on the outer nonmoving sphere with those measured experimentally. The results are discussed here in the last section in combination with the results of the present work.

2. Geometry of the boundary value problem

A viscoelastic fluid of grade two is assumed to perform steady and isochoric motion in the annular region between two eccentric spheres of radii R_1 and R_2 ($R_1 < R_2$). The bispherical system of coordinates (α, β, ϕ) is the most adequate system to solve the present problem. This system is

generated from the rectangular system of coordinates (x, y, z) by the conformal transformation

$$z + iq = ci \cot \frac{(\alpha + i\beta)}{2}; \quad i = \sqrt{-1}, \tag{1a}$$

where $q = \sqrt{x^2 + y^2}$ and $C = \text{constant}$.

Equation (1a) is equivalent to the real transformation

$$x = h \sin \alpha \cos \phi, \quad y = h \sin \alpha \sin \phi, \quad z = h \sinh \beta, \tag{1b}$$

where the scale factors for this system of coordinates are given by

$$h_\alpha = h_\beta = h = \frac{C}{\cosh \beta - \cos \alpha}, \quad h_\phi = \frac{C \sin \alpha}{\cosh \beta - \cos \alpha}.$$

In terms of bispherical coordinates the inner sphere is the surface $\beta = \beta_1$, while the outer one is $\beta = \beta_2$. The inner sphere β_1 and the outer sphere β_2 are centered on the z -axis at $z = C \coth \beta_1$ and $z = C \coth \beta_2$, respectively. The radii R_1 and R_2 are given by

$$R_1 = \frac{C}{\sinh \beta_1} \quad \text{and} \quad R_2 = \frac{C}{\sinh \beta_2}.$$

The flow field created in the space between the two spheres is due to the rotation of the inner sphere β_1 about the z -axis with angular velocity Ω , while the outer sphere β_2 remains at rest.

Symmetry about the z -axis implies that the velocity field $\dot{\mathbf{x}}$ is independent of the coordinate ϕ . Thus,

$$\dot{\mathbf{x}}(\alpha, \beta) = U(\alpha, \beta)\hat{\alpha} + V(\alpha, \beta)\hat{\beta} + W(\alpha, \beta)\hat{\phi}. \tag{2}$$

The non-slip at the boundaries β_1 and β_2 imposes boundary conditions of the form

$$\begin{aligned} \dot{\mathbf{x}}(\alpha, \beta)|_{\beta=\beta_1} &= \hat{\phi}\Omega h_\phi(\alpha, \beta_1), \\ \dot{\mathbf{x}}(\alpha, \beta)|_{\beta=\beta_2} &= 0. \end{aligned} \tag{3}$$

3. Dynamics of flow

The solution of the problem reduces to the determination of the scalar components U , V and W such that boundary conditions (3) are satisfied. Since the flow is isochoric, the equation of continuity implies that,

$$\nabla \cdot \dot{\mathbf{x}} = \frac{1}{h^3 \sin \alpha} [\partial_\alpha(h^2 \sin \alpha U) + \partial_\beta(h^2 \sin \alpha V)] = 0. \tag{4}$$

Equation (4) is satisfied identically if U and V are derivable from a stream function ψ defined by the expressions

$$U = \frac{-1}{h^2 \sin \alpha} \frac{\partial \psi}{\partial \beta} \quad \text{and} \quad V = \frac{1}{h^2 \sin \alpha} \frac{\partial \psi}{\partial \alpha},$$

or by the compact expression

$$\underline{\mathbf{u}} = U(\alpha, \beta)\hat{\alpha} + V(\alpha, \beta)\hat{\beta} = \underline{\nabla} \times \left[\hat{\phi} \frac{\psi}{h \sin \alpha} \right]. \quad (5a)$$

The velocity field $\dot{\underline{\mathbf{x}}}$ can now be expressed as

$$\dot{\underline{\mathbf{x}}} = \underline{\mathbf{u}}(\alpha, \beta) + W(\alpha, \beta)\hat{\phi} = \underline{\nabla} \times \left[\hat{\phi} \frac{\psi}{h \sin \alpha} \right] + W(\alpha, \beta)\hat{\phi}, \quad (5b)$$

Employing the decomposition of the extra stress tensor,

$$\underline{\underline{\mathbf{T}}}_E(\alpha, \beta) = \underline{\underline{\mathbf{P}}}(\alpha, \beta) + \underline{\underline{\mathbf{t}}}(\alpha, \beta)\hat{\phi} + \hat{\phi}\underline{\underline{\mathbf{t}}}(\alpha, \beta) + S(\alpha, \beta)\hat{\phi}\hat{\phi}, \quad (6)$$

to the Cauchy-dynamical equation of motion for stationary flow,

$$\underline{\nabla} \cdot \underline{\underline{\mathbf{T}}}_E(\alpha, \beta) - \underline{\nabla} p(\alpha, \beta) = \rho \dot{\underline{\mathbf{x}}} \cdot \underline{\nabla} \dot{\underline{\mathbf{x}}}, \quad (7)$$

leads to the following pair of equations

$$\underline{\nabla} \cdot (\underline{\underline{\mathbf{t}}}\hat{\phi} + \hat{\phi}\underline{\underline{\mathbf{t}}}) = \rho \underline{\mathbf{u}} \cdot \underline{\nabla} (W\hat{\phi}) \quad (8a)$$

and

$$\underline{\nabla} \cdot \underline{\underline{\mathbf{P}}} - \underline{\nabla} p = \rho \underline{\mathbf{u}} \cdot (\underline{\nabla} \underline{\mathbf{u}}). \quad (8b)$$

4. Approximate solutions for the velocity field

The problem is dealt within the frame of the retarded motion approximation [11, 12, 13]. Within this frame, the following simplifications can be used:

- (i) The constitutive equation for a fluid of grade two is defined by the expression,

$$\underline{\underline{\mathbf{T}}}_E = \mu \underline{\underline{\mathbf{A}}}_1 + \alpha_1 \underline{\underline{\mathbf{A}}}_2 + \alpha_2 \underline{\underline{\mathbf{A}}}_1^2, \quad (9)$$

where μ is the coefficient of viscosity, α_1 and α_2 are two second order material coefficients related to the normal stress differences. The tensors $\underline{\underline{\mathbf{A}}}_1$ and $\underline{\underline{\mathbf{A}}}_2$ are the first two Rivlin-Ericksen tensors defined, for stationary flow, by

$$\underline{\underline{\mathbf{A}}}_1 = \underline{\nabla} \dot{\underline{\mathbf{x}}} + (\underline{\nabla} \dot{\underline{\mathbf{x}}})^T, \quad (10a)$$

$$\underline{\underline{\mathbf{A}}}_2 = \dot{\underline{\mathbf{x}}} \cdot \underline{\nabla} \underline{\underline{\mathbf{A}}}_1 + \underline{\nabla} \dot{\underline{\mathbf{x}}} \cdot \underline{\underline{\mathbf{A}}}_1 + (\underline{\nabla} \dot{\underline{\mathbf{x}}} \cdot \underline{\underline{\mathbf{A}}}_1)^T. \quad (10b)$$

(ii) For Ω small enough, the dynamical functions W , ψ and p can be expanded into power series about the value $\Omega = 0$. Therefore,

$$\begin{aligned} W &= \sum_{k=1}^{n-1} \Omega^k W_k + O(\Omega^n), \\ \psi &= \sum_{k=1}^{n-1} \Omega^k \psi_k + O(\Omega^n), \\ p &= \sum_{k=1}^{n-1} \Omega^k p_k + O(\Omega^n). \end{aligned} \tag{11}$$

The method of perturbation may be summarized into the following steps:

- (a) Substitution from (11) into (10a) and (10b) and further into (9) gives an expression for the extra-stress tensor into powers of Ω .
- (b) After carrying out the decomposition, the result can be substituted into the pair of equations (8a) and (8b).
- (c) Equating the coefficients of equal powers of Ω produces a set of successive partial differential equations for the determination of the velocity components and the pressure function in successive order.

In order to preserve the continuity of the physical content, we carry out the detailed calculations of the method of approximation in Appendix A. Here, we give the final results of these calculations.

4.1. First order approximation

The velocity field up to $o(\Omega^2)$ is given by the equation (A8) of Appendix A,

$$\dot{\mathbf{x}} = \Omega W_1(\alpha, \beta) \hat{\phi} + O(\Omega^2), \tag{12a}$$

where

$$\begin{aligned} W_1 &= 2^{3/2} C (\cosh \beta - \cos \alpha)^{1/2} \\ &\times \sum_{n=1}^{\infty} \left[\frac{\sinh(n + 1/2)(\beta - \beta_2)}{\sinh(n + 1/2)\delta e^{(n+1/2)\beta_1}} \right] P_n^1(\cos \alpha). \end{aligned} \tag{12b}$$

The function P_n^1 is being the associated Legendre polynomial of order n and degree one.

4.2. Second order approximation

As shown in Appendix A, equation (A22), the velocity field up to $O(\Omega^3)$ is given by the expression

$$\dot{\mathbf{x}} = \Omega W_1(\alpha, \beta) \hat{\phi} + \Omega^2 \mathbf{u}_2 + O(\Omega^3), \tag{13}$$

where W_1 is given by equation (12b) and \underline{u}_2 is determined by the stream function ψ_2 ,

$$\underline{u}_2 = \underline{V} \times \left[\hat{\phi} \frac{\psi_2}{h \sin \alpha} \right]. \tag{14}$$

The stream function ψ_2 is the solution of the boundary value problem, equations (A19) and (A20), of the form

$$\begin{aligned} \nabla^4 \left(\frac{\psi_2 \hat{\phi}}{h \sin \alpha} \right) + 2 \frac{(\alpha_1 + \alpha_2)}{\mu h^2} \left\{ \partial_\alpha \left[\frac{\sinh \beta}{hC} F \right] \right. \\ \left. - \partial_\beta \left[\frac{1 - \cosh \beta \cos \alpha}{hC \sin \alpha} F \right] \right\} \hat{\phi} = 0, \end{aligned} \tag{15}$$

where

$$\begin{aligned} F = (W_{1,\alpha})^2 + (W_{1,\beta})^2 + \frac{2h(1 - \cosh \beta \cos \alpha)}{C \sin \alpha} W_1 W_{1,\alpha} \\ + \frac{2h \sinh \beta}{C} W_1 W_{1,\beta} + \frac{1}{\sin^2 \alpha} W_1^2. \end{aligned} \tag{16}$$

The function ψ_2 is subjected to the boundary condition

$$\psi_2(\alpha, \beta_2) = \psi_{2,\beta}(\alpha, \beta_2) = 0. \tag{17}$$

Due to the complex nature of the boundary value problem defined by equations (15) and (17), its solution is deferred to a future work. However, it can be concluded that the second order approximation leads to a secondary flow field $\underline{u}_2(\alpha, \beta)$ whose components lie in the directions of the α and β coordinates.

5. Distribution of stresses and total forces and torques acting on the outer sphere

The surface traction at the boundary $\beta = \beta_2$ is defined by

$$\underline{s}(\alpha, \beta_2) = -p(\alpha, \beta_2) \hat{\beta} + \underline{T}_E(\alpha, \beta_2) \cdot \hat{\beta}. \tag{18}$$

This expression describes the stress vector per unit area on the surface of a spherical shell $\beta = \beta_2$.

The velocity field, as expressed by equation (12a) leads to the following expression

$$(\underline{A}_1) = \Omega \begin{pmatrix} 0 & 0 & \Gamma_\alpha \\ 0 & 0 & \Gamma_\beta \\ \Gamma_\alpha & \Gamma_\beta & 0 \end{pmatrix} + O(\Omega^2), \tag{19}$$

where

$$\Gamma_\alpha = h^{-1} \left(W_{1,\alpha} + \frac{h(1 - \cosh \beta \cos \alpha)}{C \sin \alpha} W_1 \right),$$

$$\Gamma_\beta = h^{-1} \left(W_{1,\beta} + \frac{h \sinh \beta}{C} W_1 \right).$$

The surface tractions due to this tensor field is given as

$$\underline{A}_1 \cdot \hat{\beta} = \Omega \Gamma_\alpha \hat{\phi}. \tag{20}$$

Consequently, the tensor \underline{A}_2 ,

$$\underline{A}_2 = \dot{\underline{x}} \cdot \nabla \underline{A}_1 + \nabla \dot{\underline{x}} \cdot \underline{A}_1 + (\nabla \dot{\underline{x}} \cdot \underline{A}_1)^T, \tag{21}$$

can be written in the form

$$(\underline{A}_2) = 2\Omega^2 \begin{pmatrix} \Gamma_\alpha^2 & \Gamma_\alpha \Gamma_\beta & 0 \\ \Gamma_\alpha \Gamma_\beta & \Gamma_\beta^2 & 0 \\ 0 & 0 & 0 \end{pmatrix} + O(\Omega^3). \tag{22}$$

The surface traction due to the tensor field \underline{A}_2 is therefore given by

$$\underline{A}_2 \cdot \hat{\beta} = 2\Omega^2 (\Gamma_\alpha \Gamma_\beta \hat{\alpha} + \Gamma_\beta^2 \hat{\beta}) + O(\Omega^3). \tag{23}$$

The tensor \underline{A}_1^2 is given by

$$(\underline{A}_1^2) = \Omega^2 \begin{pmatrix} \Gamma_\alpha^2 & \Gamma_\alpha \Gamma_\beta & 0 \\ \Gamma_\alpha \Gamma_\beta & \Gamma_\beta^2 & 0 \\ 0 & 0 & \Gamma_\alpha^2 + \Gamma_\beta^2 \end{pmatrix} + O(\Omega^3). \tag{24}$$

The surface traction due to \underline{A}_1^2 is,

$$\underline{A}_1^2 \cdot \hat{\beta} = \Omega^2 (\Gamma_\alpha \Gamma_\beta \hat{\alpha} + \Gamma_\beta^2 \hat{\beta}) + O(\Omega^3). \tag{25}$$

The substitution of equations (20), (23) and (25) into equation (18) leads to the following formula for the second order stress vector $\underline{s}(\alpha, \beta)$ at any arbitrary surface $\beta = \text{const}$. Therefore,

$$\underline{s}(\alpha, \beta) = S_\alpha \hat{\alpha} + S_\beta \hat{\beta} + S_\phi \hat{\phi}, \tag{26}$$

where,

$$S_\alpha = \Omega^2 (\alpha_2 + 2\alpha_1) \Gamma_\alpha \Gamma_\beta + O(\Omega^3),$$

$$S_\beta = \Omega^2 (\alpha_2 + 2\alpha_1) \Gamma_\beta^2 + O(\Omega^3),$$

$$S_\phi = \Omega \mu \Gamma_\beta + O(\Omega^3).$$

At the surface of the outer sphere, $\beta = \beta_2$, the α -component, i.e. S_α , vanishes, since $W_1|_{\beta_2} = W_{1,\alpha}|_{\beta_2} = 0$. Equation (26) reduces to

$$\underline{s}(\alpha, \beta_2) = [S_\beta \hat{\beta} + S_\phi \hat{\phi}]_{\beta = \beta_2}, \tag{27}$$

where

$$S_\beta|_{\beta_2} = \Omega^2(\alpha_2 + 2\alpha_1)(h^{-2}W_{1,\beta}^2)|_{\beta_2} + O(\Omega^3). \tag{28a}$$

$$S_\phi|_{\beta_2} = \Omega\mu h^{-1}(W_{1,\beta})|_{\beta_2} + O(\Omega^3). \tag{28b}$$

The resultant force up to the second order acting on the external sphere β_2 has the form

$$\underline{F} = \int_0^{2\pi} d\phi \int_0^\pi d\alpha [\underline{s}(\alpha, \beta)h^2 \sin \alpha]_{\beta_2}. \tag{29}$$

Since experimental measurements may be carried out about the axis of rotation and any two arbitrary axes perpendicular to it, the total forces and torques are expanded in the X_1 , X_2 and X_3 -directions, where X_3 is taken along the symmetry axis. Hence,

$$\underline{s}(\alpha, \beta_2) = S_1 \hat{x}_1 + S_2 \hat{x}_2 + S_3 \hat{x}_3, \tag{30a}$$

where, after transforming S_β and S_ϕ to S_1 , S_2 and S_3 we obtain

$$\begin{aligned} S_1 &= \left[-\frac{h}{C} \cos \phi \sinh \beta \sin \alpha S_\beta - \sin \phi S_\phi \right]_{\beta = \beta_2}, \\ S_2 &= \left[-\frac{h}{C} \sin \phi \sinh \beta \sin \alpha S_\beta - \cos \phi S_\phi \right]_{\beta = \beta_2}, \\ S_3 &= \left[-\frac{h}{c} (\cosh \beta \cos \alpha - 1) S_\beta \right]_{\beta = \beta_2}. \end{aligned} \tag{31}$$

Substituting from equation (30a) into equation (29); we get three integrals for the three components \underline{F} .

The X_1 -component of \underline{F} is given by

$$F_1(\beta_2) = \int_0^{2\pi} d\phi \int_0^\pi d\alpha [S_1(\alpha, \beta_2)h^2 \sin \alpha]_{\beta = \beta_2} = 0, \tag{32}$$

while the second component of \underline{F} is determined by

$$F_2(\beta_2) = \int_0^{2\pi} d\phi \int_0^\pi d\alpha [S_2(\alpha, \beta_2)h^2 \sin \alpha]_{\beta = \beta_2} = 0. \tag{33}$$

The only non-vanishing component \underline{F} is F_3 component,

$$F_3(\beta_2) = \int_0^{2\pi} d\phi \int_0^\pi d\alpha [S_3(\alpha, \beta_2)h^2 \sin \alpha]_{\beta = \beta_2}.$$

Therefore

$$\begin{aligned}
 F_3(\beta_2) &= 2\pi(\alpha_2 + 2\alpha_1)\Omega^2 \\
 &\quad \times \int_0^\pi d\alpha \left[\frac{h \sin \alpha}{C} (1 - \cosh \beta \cos \alpha) W_{1,\beta}^2 \right]_{\beta=\beta_2} \\
 F_3(\beta_2) &= 4\pi(\alpha_2 + 2\alpha_1)C^2\Omega^2 \sum_{n=1}^\infty \frac{2n(n+1) e^{-(2n+1)\beta_1}}{\sinh(n+1/2)\delta} \\
 &\quad \times \left[\frac{2n+1}{\sinh(n+1/2)\delta} - 2 \frac{(n+2) \cosh \beta_2}{\sinh(n+3/2)\delta e^{\beta_1}} \right]. \tag{34}
 \end{aligned}$$

Determination of the resultant torques acting on the outer sphere

The non-vanishing resultant torque, due to the surface traction component S_ϕ about the axis of symmetry, is given by

$$M_Z = C \int_0^{2\pi} d\phi \int_0^\pi d\alpha \left[\frac{\sin \alpha}{\cosh \beta - \cos \alpha} S_\phi(\alpha, \beta_2) h^2(\alpha, \beta_2) \sin \alpha \right].$$

Substituting by $S_\phi(\alpha, \beta_2)$ from equation (28b) in the last equation, the resultant torque acting on the outer sphere is given by

$$\begin{aligned}
 M_z &= 2^{3/2}\pi\Omega\mu C^3 \sum_{n=1}^\infty \frac{(2n+1) e^{-(n+1/2)\beta_1}}{\sinh(n+1/2)\delta} \\
 &\quad \times \int_0^\pi d\alpha \left[\frac{\sin^2 \alpha}{(\cosh \beta_2 - \cos \alpha)^{1.5}} p_n^1(\cos \alpha) \right]
 \end{aligned}$$

performing the last integral, we get,

$$M_z = -16\pi\Omega\mu C^3 \sum_{n=1}^\infty \frac{n(n+1) e^{-(n+1/2)(\beta_1+\beta_2)}}{\sinh(n+1/2)\delta}. \tag{35}$$

6. Discussion

The present work is devoted to the study of the flow of viscoelastic fluids in the annular region between two eccentric spheres. The first order velocity field described by equation (12b) is plotted versus y , where $y = (\beta_1 - \beta)/(\beta_1 - \beta_2)$, in Fig. 1. The second order equation of motion, whose solution is deferred to a future work, reveals the existence of a secondary flow in the meridian surfaces defined by $\phi = \text{const}$.

The resultant torque given by equation (35) may be expressed in terms of geometrical parameters, which are appropriate for practical purposes.

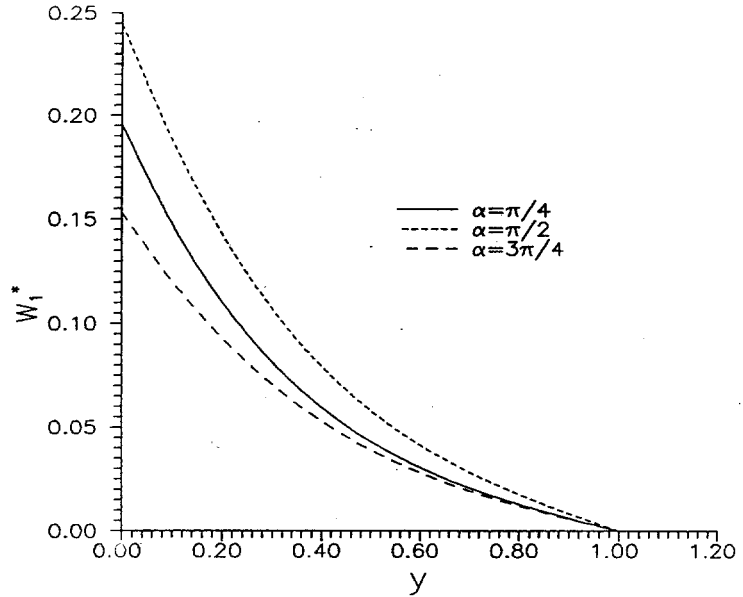

Figure 1
 $W_1^* = W_1/(2\sqrt{2}C)$ versus y where α is taken as a parameter.

These parameters are; namely, $X = R_1/R_2$ and the dimensionless eccentricity $\varepsilon = e/(R_2 - R_1)$, where e is the distance between the two centers of the spheres. The obtained solution is

$$M^* = \frac{M_z}{M_0} = \sum_{n=1}^{\infty} \frac{2^{2n}(X\varepsilon)^{2(n-1)}n(n+1)(1-X^3)\Delta^3}{A^{2n+1} - (BX)^{2n+1}}, \tag{36}$$

where

$$M_0 = -8\pi\Omega\mu \frac{R_1^3}{1-X^3}$$

≡ the torque in the concentric case [16],

$$\Delta^2 = (1 - \varepsilon^2)[(1 + X)^2 - \varepsilon^2(1 - X)^2],$$

$$A = 1 + X - \varepsilon^2(1 - X) + \Delta,$$

$$B = 1 + X + \varepsilon^2(1 - X) + \Delta,$$

$$\sinh \delta = \frac{(1 - X)\Delta}{2X}.$$

Figure 2 represents M^* versus ε where X is used as a parameter, while Fig. 3 represents a plot between M^* and X where ε plays the role of a

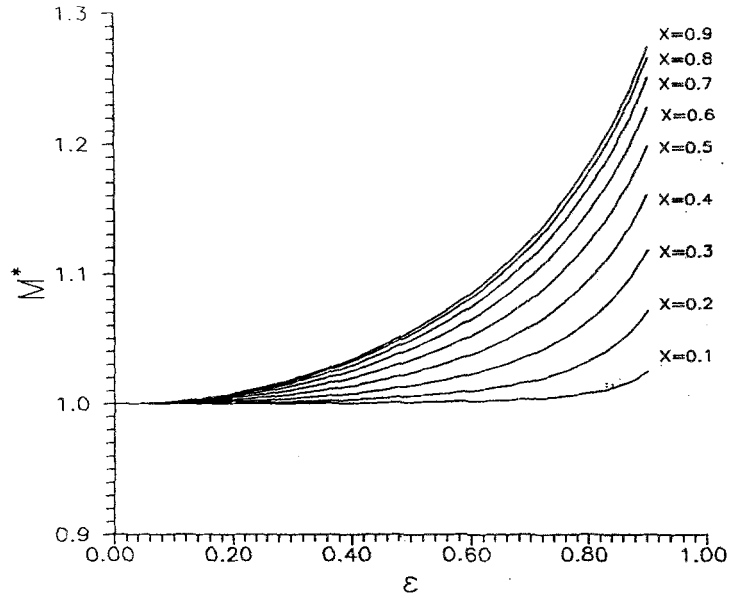

Figure 2
The torque $M^* = M_z/M_0$ plotted versus ϵ where X is taken as a parameter.

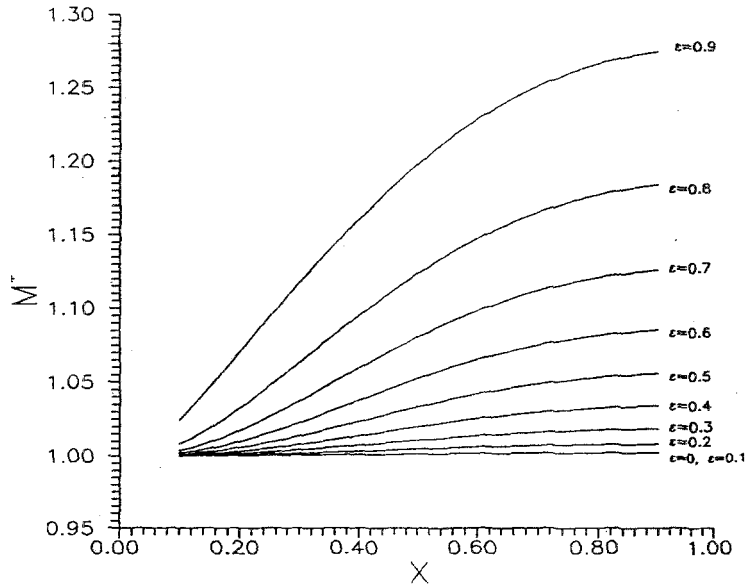

Figure 3
The torque $M^* = M_z/M_0$ plotted versus X where ϵ is taken as a parameter.

parameter. These two figures show that M^* increases monotonically with either ε or X .

Munson [9] solved the present problem for Navier-Stokes fluid. He employed the usual spherical polar coordinates for the solution of the equation of motion. Since this system is not adequate for the present boundary value problem, a series of approximations is used to get the final solution. Menguturk and Munson [10] constructed an experimental set up to measure the torque on the outer sphere in order to compare it with their theoretical formula. This formula, expressed in terms of the same parameters employed in the present work, has the form

$$M^* = \frac{M_z}{M_0} = 1 + \frac{3X^3(1 - X)^2}{(1 - X^3)(1 - X^5)} \varepsilon^2. \tag{37}$$

Noteworthy is that in the case of Navier-Stokes fluid, the torque about the axis of symmetry is the only effect which appears to act on the outer sphere. This torque is being the first order term in the case of viscoelastic fluid. The theoretical data obtained in the present work, equation (36), in addition to the theoretical data due to Munson, equation (37), are presented in Fig. 4 in comparison with the experimental data due to Menguturk and Munson [10]. Our theoretical curves show a better fitting to the experimental data than those due to Munson specially at large values of ε . These deviations may be attributed to the approximations made to fit the solution in terms of spherical polar coordinates to the boundary value problem. To have better insight in this context, we give an approximate form for equation (36) for small eccentricity,

$$M^* = \frac{M_z}{M_0} = 1 + \frac{3X^3(1 - X^3)}{(1 + X)^2(1 - X^5)} \varepsilon^2. \tag{37}$$

Equations (37) and (38) are basically different, however, both equations reduce to $M^* = 1$ when $\varepsilon = 0$; i.e., both equations reduce to the concentric case.

As an effect of second order, a resultant force in the direction of the axis of symmetry appears which tries to push the outer sphere from the eccentric to the concentric position. This force is proportional to the material parameter ($\alpha_2 + 2\alpha_1$) or to the second normal stress difference coefficient. Figure 5 represents the normalized form of F_Z given by

$$\begin{aligned} F_z^* &= \frac{F_3}{4\pi\Omega^2(\alpha_2 + 2\alpha_1)R_1^2} \\ &= \sum_{n=1}^{\infty} \frac{2^{2n}n(n+1)(X\varepsilon)^{2n-1}\Delta^2}{A^{2n+1} \sinh(n+1/2)\delta} \\ &\quad \times \left[\frac{2n+1}{\sinh(n+1/2)\delta} - \frac{2(n+2)X[X+1+\varepsilon^2(1-x)]}{A \sinh(n+3/2)\delta} \right], \end{aligned} \tag{39}$$

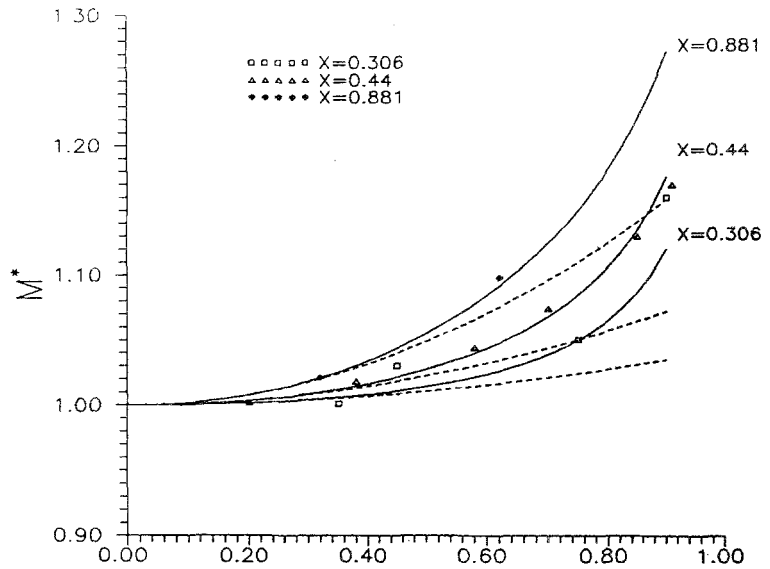

Figure 4
The torque M^* plotted versus ε in comparison with Ref. 9 where X is taken as a parameter. Dashed line and symbols represent theoretical and experimental data from Ref. 9.

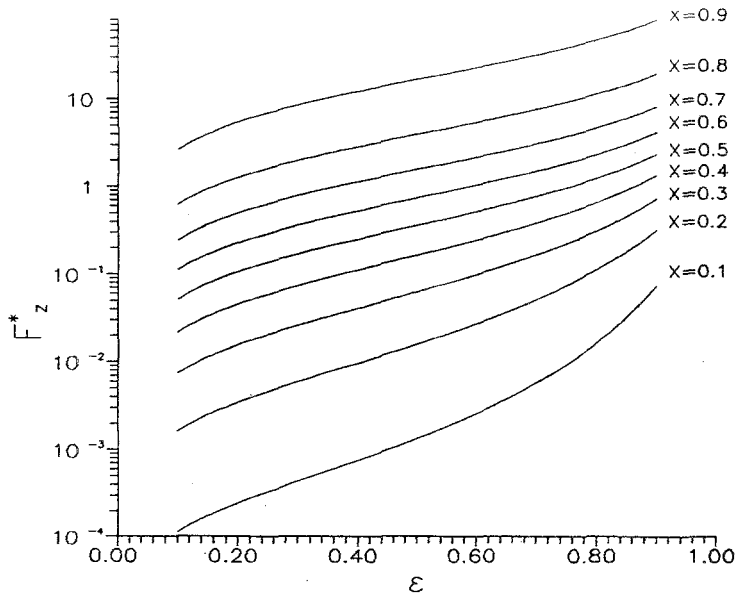

Fig.(5): The force F_z^* plotted versus ε where X is taken as a parameter.

Figure 5
The force F_z^* plotted versus ε where X is taken as a parameter.

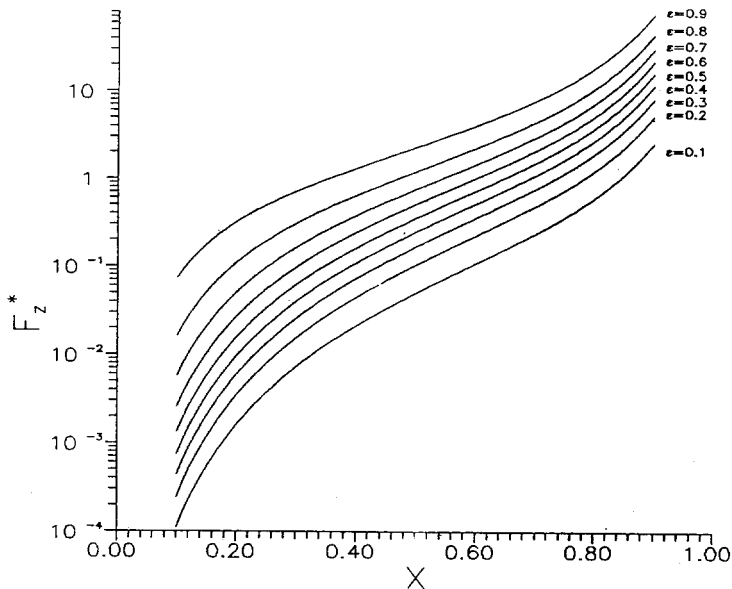

Figure 6
The force F_z^* plotted versus X where ϵ is taken as a parameter.

as a function of ϵ while X is taken as a parameter. On the other hand, F_z^* is plotted versus X in Fig. 6, where ϵ is used as a parameter. The curves reveal that F_z^* increases monotonically with either ϵ or X . In the limit $\epsilon = 0$; i.e. the concentric case, F_z^* tends to zero.

The results of the present work suggests the possibility of constructing a rheometer which is able to determine both the second normal stress difference and the viscosity coefficients in the same set up.

7. Estimation of the error due to the shaft*

In the absence of the shaft, the slow rotation of the inner sphere about the z -axis is supposed to create a laminar velocity field whose magnitude close to the surface of the sphere is roughly

$$v_\phi = \Omega r \sin \theta.$$

This velocity component is the azimuthal velocity in the ϕ -direction. The shear stress due to this component, at the surface can be estimated as

$$\tau|_{r=R_1} = \mu \left. \frac{\partial v_\phi}{\partial r} \right|_{r=R_1} = \mu \Omega \sin \theta.$$

* This estimation is carried out due to a suggestion of the reviewer.

The power required to overcome this stress in order to rotate the sphere is approximately

$$\begin{aligned}
 P &= \int_0^{2\pi} d\phi \int_0^\pi d\theta [\tau v_\phi]_{r=R_1} R_1^2 \sin \theta \\
 &= \int_0^{2\pi} d\phi \int_0^\pi d\theta (\mu \Omega \sin \theta) (\Omega R_1 \sin \theta) R_1^2 \sin \theta \\
 &= \frac{8}{3} \pi \mu \Omega^2 R_1^3.
 \end{aligned}$$

This power is responsible for the torque acting on the outer sphere.

In the presence of the shaft, an additional velocity field is created due to its rotation. The tangential velocity component of this field in the neighborhood of its surface is

$$\tilde{v}_\phi = \Omega R_S,$$

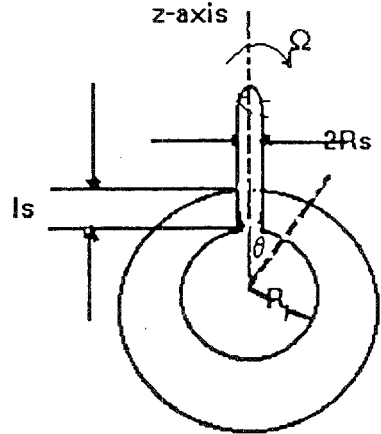

where R_S is the radius of the shaft. Similarly, the stress created by this field requires an amount of power to rotate the shaft. This power is of magnitude

$$\tilde{P} = \int_0^{2\pi} d\phi \int_0^{I_S} d\theta [\tilde{\tau} \tilde{v}_\phi]_{r=R_S} R_1^2 \sin \theta = 2\pi \mu \Omega^2 R_S^2 I_S.$$

The error caused by the shaft can be estimated as the ratio

$$\frac{\tilde{P}}{P} \leq \frac{3R_S^2 I_S}{4R_1^3}.$$

Thus, using a shaft of much smaller radius than R_1 , and letting the narrower space between the two spheres be at the side of the shaft, may reduce this error. For example, let the radius of the inner sphere be

$R_1 = 2$ cm and the radius of the outer sphere be $R_2 = 2.5$ cm; then $l_s = R_2 - R_1 = 0.5$ cm. If the radius of the shaft is 0.16 cm, then

$$\frac{\tilde{P}}{P} \leq \frac{3(0.16)^2(0.5)}{4(2)^3} \leq 1.2 \times 10^{-3}.$$

Appendix A

A.1. First order approximation

The extra-stress up to the order $O(\Omega^2)$ is given by,

$$\underline{\underline{T}}_E = \Omega\mu[\underline{V}\underline{u} + (\underline{V}\underline{u})^T + \underline{V}(W\hat{\phi}) + (\underline{V}(W\hat{\phi}))^T] + O(\Omega^2),$$

which by comparison with the decomposition equation (6) implies that,

$$\underline{t} = \Omega\mu[\Gamma_\alpha\hat{\alpha} + \Gamma_\beta\hat{\beta}] + O(\Omega^2), \quad (\text{A1})$$

and

$$\underline{\underline{P}} = \Omega\mu[\underline{V}\underline{u}_1 + (\underline{V}\underline{u}_1)^T] + O(\Omega^2). \quad (\text{A2})$$

Substitution from equation (11) and equation (A1) into equation (8a) and equating equal powers of Ω leads to

$$\nabla^2(W_1\hat{\phi}) = 0. \quad (\text{A3})$$

The boundary conditions, equation (3), imposed on \underline{x} require that W_1 is subject to the conditions,

$$W_1(\alpha, \beta_1) = h_\phi(\alpha, \beta_1), \quad W_1(\alpha, \beta_2) = 0, \quad (\text{A4})$$

hence W_1 is completely determined by the boundary value problem defined by equations (A3) and (A4).

Substituting again from equation (11) and equation (A2) into equation (8b) and equating equal powers of Ω , we obtain

$$\mu\nabla^2\underline{u}_1 - \underline{V}\mathcal{X}_1 = 0.$$

By substitution from equation (5a), $\underline{u}_1 = \underline{V} \times [\hat{\phi}(\psi_1/h \sin \alpha)]$, and applying the curl operator to the resultant equation, it reduces to

$$\nabla^4\left(\frac{\psi_1\hat{\phi}}{h \sin \alpha}\right) = 0. \quad (\text{A5})$$

The boundary conditions imposed on ψ_1 due to equation (3) may be stated as

$$\psi_1|_{\beta=\beta_1,\beta_2} = \quad \text{and} \quad \psi_{1,\beta}|_{\beta=\beta_1,\beta_2} = 0. \quad (\text{A6})$$

It can be easily shown that the only solution for the boundary value problem defined by equations (A5) and (A6) is the trivial solution $\psi_1 = 0$. Up to the first order, the velocity field reduces to,

$$\dot{x} = \Omega W_1(\alpha, \beta)\hat{\phi} + O(\Omega^2), \tag{A7}$$

where W_1 is defined by the boundary value problem (A3) and (A4). Equation (A3) has the explicit form

$$W_{1,2xx} + W_{1,\beta\beta} + \frac{h(\cosh \beta \cos \alpha - 1)}{C \sin \alpha} W_{1,x} - \frac{h \sinh \beta}{C} W_{1,\beta} - \frac{1}{\sin^2 \alpha} W_1 = 0.$$

Employing the R -separation method [14, 15] to get a solution of the last equation which satisfies the boundary condition (A4), we obtain

$$W_1 = 2^{3/2}C(\cosh \beta - \cos \alpha)^{1/2} \times \sum_{n=1}^{\infty} \left[\frac{\sinh(n + 1/2)(\beta - \beta_2)}{\sinh(n + 1/2)\delta e^{(n + 1/2)\beta_1}} \right] P_n^1(\cos \alpha). \tag{A8}$$

A.2. Second-order approximation

Second-order calculations require the determination of $\underline{V} \cdot \underline{T}_E$ up to $O(\Omega^3)$,

$$\underline{V} \cdot \underline{T}_E = [\mu \underline{V} \cdot \underline{A}_1] + [\alpha_1 \underline{V} \cdot \underline{A}_2 + \alpha_2 \underline{V} \cdot \underline{A}_1^2]. \tag{A9}$$

To determine this expression, we have to calculate $\underline{V} \cdot \underline{A}_2$ and $\underline{V} \cdot \underline{A}_1^2$. During our calculations, we have to notice that from equations (10a) and (A3) up to the $O(\Omega^2)$ $\underline{V} \cdot \underline{A}_1 = 0$.

Consequently,

$$\underline{V} \cdot \underline{A}_2 = \underline{A}_1 : \underline{V} \underline{V} \dot{x} + 2 \underline{V} \underline{V} \dot{x} : \underline{A}_1 = 2 \underline{V} \dot{x} : \underline{V} \underline{V} \dot{x} + \frac{1}{2} \underline{V} [\underline{A}_1 : \underline{A}_1]. \tag{A10}$$

Similarly,

$$\underline{V} \cdot \underline{A}_1^2 = 2 \underline{V} \dot{x} : \underline{V} \underline{V} \dot{x} + \frac{1}{4} \underline{V} [\underline{A}_1 : \underline{A}_1]. \tag{A11}$$

The substitution of equations (A10) and (A11) into equation (A9) gives

$$\underline{V} \cdot \underline{T}_E = [\mu \underline{V} \cdot \underline{A}_1] + \left[2(\alpha_1 + \alpha_2) \underline{V} \dot{x} : \underline{V} \underline{V} \dot{x} + \frac{1}{4} (\alpha_2 + 2\alpha_1) \underline{V} (\underline{A}_1 : \underline{A}_1) \right] + O(\Omega^3). \tag{A12}$$

Substituting from equation (11) and (A12) into the Cauchy dynamical equation (7) and equating equal powers of Ω^2 , we obtain

$$\begin{aligned} &\mu[\nabla^2(W_2\hat{\phi}) + \nabla^2\mathbf{u}_2] + 2(\alpha_1 + \alpha_2)\underline{\mathbb{V}}\dot{\mathbf{x}}:\underline{\mathbb{V}}\underline{\mathbb{V}}\dot{\mathbf{x}} \\ &+ \underline{\mathbb{V}}\left(\frac{1}{4}(\alpha_2 + \alpha_1)\mathbb{A}_1:\mathbb{A}_1 - \mathcal{X}_2\right) = 0. \end{aligned} \tag{A13}$$

Now, we have to compute the expression $\underline{\mathbb{V}}\dot{\mathbf{x}}:\underline{\mathbb{V}}\underline{\mathbb{V}}\dot{\mathbf{x}}$ for $\dot{\mathbf{x}} = \hat{\phi}W_1(\alpha, \beta)$ in terms of bispherical coordinates.

Hence,

$$\underline{\mathbb{V}}\dot{\mathbf{x}} = \hat{\alpha}\hat{\phi}C_1 + \hat{\beta}\hat{\phi}C_2 + \hat{\phi}\hat{\alpha}C_3 + \hat{\phi}\hat{\beta}C_4, \tag{A14}$$

where

$$\begin{aligned} C_1 &= h^{-1}W_{1,\alpha}, & C_2 &= h^{-1}W_{1,\beta}, \\ C_3 &= \frac{1 - \cosh \beta \cos \alpha}{C \sin \alpha} W_1 & \text{and} & \quad C_4 = \frac{\sinh \beta}{C} W_1. \end{aligned}$$

Consequently,

$$\underline{\mathbb{V}}\underline{\mathbb{V}}\dot{\mathbf{x}} = h^{-1}\left[\hat{\alpha}\hat{\partial}_\alpha + \hat{\beta}\hat{\partial}_\beta + \frac{\hat{\phi}}{\sin \alpha} \hat{\partial}_\phi\right][\hat{\alpha}\hat{\phi}C_1 + \hat{\beta}\hat{\phi}C_2 + \hat{\phi}\hat{\alpha}C_3 + \hat{\phi}\hat{\beta}C_4]. \tag{A15}$$

The conjunction of (A13) and (A14) gives,

$$\begin{aligned} \underline{\mathbb{V}}\dot{\mathbf{x}}:\underline{\mathbb{V}}\underline{\mathbb{V}}\dot{\mathbf{x}} &= h^{-1}\left\{\hat{\alpha}\left[\frac{h(1 - \cosh \beta \cos \alpha)}{C \sin \alpha} (C_1^2 + C_2^2 + C_1C_3)\right.\right. \\ &\quad \left.+\frac{h \sinh \beta}{C} (C_2C_3 - C_3C_4) + \frac{h \sin \alpha}{C} C_4^2 + C_3C_{3,\alpha} + C_4C_{3,\beta}\right] \\ &\quad + \hat{\beta}\left[\frac{h \sinh \beta}{C} (C_1^2 + C_2^2 + C_2C_4 + C_3^2)\right. \\ &\quad \left.+\frac{h(1 - \cosh \beta \cos \alpha)}{C \sin \alpha} C_1C_4\right. \\ &\quad \left.-\frac{h \sin \alpha}{C} C_3C_4 + C_3C_{4,\alpha} + C_4C_{4,\beta}\right]\left.\right\}. \end{aligned} \tag{A16}$$

Substituting by C_1, C_2, C_3 and C_4 into equation (A16) we obtain

$$\underline{\mathbb{V}}\dot{\mathbf{x}} : \underline{\mathbb{V}}\underline{\mathbb{V}}\dot{\mathbf{x}} = h^{-2}F(\alpha, \beta)\left[\frac{(1 - \cosh \beta \cos \alpha)}{C \sin \alpha} \hat{\alpha} + \frac{\sinh \beta}{C} \hat{\beta}\right], \tag{A17}$$

where $F(\alpha, \beta)$ is given by the expression,

$$F(\alpha, \beta) = W_{1,\alpha}^2 + W_{1,\beta}^2 + 2 \frac{h(1 - \cosh \beta \cos \alpha)}{C \sin \alpha} W_1 W_{1,\alpha} + 2 \frac{h \sin \beta}{C} W_1 W_{1,\beta} + \frac{1}{\sin^2 \alpha} W_1^2.$$

The expression (A16) is entirely in $\alpha\beta$ -surface, so that equation (A12) decomposes into,

$$\nabla^2[W_2(\alpha, \beta)\hat{\phi}] = 0, \tag{A18}$$

and

$$\mu \nabla^2 \underline{u}_2 + 2 \frac{\alpha_1 + \alpha_2}{h^2} F(\alpha, \beta) \left[\frac{1 - \cosh \beta \cos \alpha}{C \sin \alpha} \hat{\alpha} + \frac{\sinh \beta}{C} \hat{\beta} \right] - \nabla \left(\frac{1}{4} (2\alpha_1 + \alpha_2) \underline{A}_1 : \underline{A}_1 - \mathcal{X}_2 \right) = 0. \tag{A19}$$

The boundary conditions imposed on W_2 are, $W_2(\alpha, \beta_1) = W_2(\alpha, \beta_2) = 0$, such that the only solution of (A17) which satisfies these conditions is the identity $W_2 = 0$. Thus, the second order approximation reduces to the solution of equation (A18) under the relevant conditions imposed at the boundaries. Applying the curl operator to equation (A18) and substituting $\underline{u}_2 = \nabla \times (\hat{\phi}(\psi_2/h \sin \alpha))$, we obtain,

$$\nabla^4 \left(\hat{\phi} \frac{\psi_2}{h \sin \alpha} \right) + 2 \frac{\alpha_1 + \alpha_2}{\mu h^2} \left\{ \partial_\alpha \left[\frac{\sinh \beta}{hC} F(\alpha, \beta) \right] - \partial_\beta \left[\frac{1 - \cosh \beta \cos \alpha}{hC \sin \alpha} F(\alpha, \beta) \right] \right\} \hat{\phi} = 0.$$

The boundary conditions imposed on (A19) are,

$$\psi_2(\alpha, \beta_1) = \psi_2(\alpha, \beta_2) = \psi_{2,\beta}(\alpha, \beta_1) = \psi_{2,\beta}(\alpha, \beta_2) = 0. \tag{A21}$$

Therefore the velocity field $\underline{\dot{x}}$ up to $O(\Omega^3)$ is given by

$$\underline{\dot{x}} = \Omega W_1(\alpha, \beta)\hat{\phi} + \Omega^2 \underline{u}_2 + O(\Omega^3). \tag{A22}$$

References

[1] Giesekus, H. W., *Rheol. Acta* 3, 59–71 (1963).
 [2] Abdel Wahab, M., *Investigation of boundary value problem of the measuring of viscoelastic properties of fluids*, Doctor Thesis, Faculty of Science, Benha, Egypt 1990.
 [3] Abdel Wahab, M., Giesekus, H. W. and Zidan, M., *A new eccentric-cylinder rheometer*, *Rheol. Acta* 29, 16–22 (1990).
 [4] El-Bakry, M. Y., *Study of flow problems which is of special significance to rheometry*. M.Sc. Thesis, Faculty of Science, Benha, Egypt 1993.

- [5] Kovatcheva, N. T., Christov, C. I. and Zapryanov, Z. D., *ZAMM. Z. Angew. Math. Mech.* 68 (2): 121–125 (1988).
- [6] Jeffery, G. B., *Proc. London Math. Soc.* (2) 14, 327 (1915).
- [7] Stimson, M. and Jeffery, G. B., *Proc. Roy. Soc. A* 3, 110 (1926).
- [8] Majumdar, S. R., *J. Phys. Soc. Japan* 26, 827–840 (1969).
- [9] Munson, B. R., *Phys. Fluids* 17, 528–531 (1974).
- [10] Menguturk, M. and Munson, B. R., *Phys. Fluids* 18, 128–129 (1975).
- [11] Noll, W., *Arch. Rational Mech. Anal.* 2, 197–226 (1958).
- [12] Truesdell, C., *The Elements of Continuum Mechanics*. Springer-Verlag, Berlin, Heidelberg, New York 1966.
- [13] Rivlin, R. S. and Ericksen, J. L., *J. Rat. Mech. Anal.* 4, 323–425 (1955).
- [14] Morse, P. M. and Feshbach, H., *Methods of Theoretical Physics*, Part I, II. McGraw-Hill, Inc., New York, Toronto, London 1953.
- [15] Moon, P. and Spencer, D. E., *Field Theory for Engineers*, D. Van Nostrand Company, Inc. Princeton, New York, New Jersey, Toronto, London 1961.
- [16] Landau, L. D. and Lifshitz, E. M., *Fluid Mechanics* (Course of Theoretical Phys.) Vol. 6 second edition 1987.

Abstract

The isothermal, stationary and isochoric flow of a fluid of grade two between a pair of rotating eccentric spheres is investigated. The equations of motion of first and second order are formulated and solved for the first order only. However, the equation of second order indicates the presence of secondary flow. The stress distributions are computed and used to determine the resultant forces and torques acting on the stationary outer sphere. An important result for rheometry is that the resultant torques can be used to determine the coefficient of viscosity, while the resultant force in the direction of the axis of symmetry may be employed to determine the second normal stress difference.

(Received June 13, 1994)